



(V) Preliminary Specification
() Final Specification

Module	27" Color TFT-LCD
Model Name	M270HW01 V2

Customer	Date
_____	_____
Approved by	
_____	_____
<p>Note: This Specification is subject to change without notice.</p>	

Approved by	Date
<u>Winnie Chang</u>	<u>2011/06/02</u>
Prepared by	
<u>Hannie Yeh</u>	<u>2011/06/02</u>
<p>Desktop Display Business Group / AU Optronics corporation</p>	

Contents

1.0 Handling Precautions	4
2.0 General Description	5
2.1 Display Characteristics.....	5
2.2 Optical Characteristics	6
3.0 Functional Block Diagram	10
4.0 Absolute Maximum Ratings	11
4.1 TFT LCD Module.....	11
4.2 Backlight Unit	11
4.3 Absolute Ratings of Environment.....	11
5.0 Electrical characteristics	12
5.1 TFT LCD Module.....	12
5.1.1 Power Specification	12
5.1.2 Signal Electrical Characteristics	13
5.2 Backlight Unit	15
6.0 Signal Characteristic.....	16
6.1 Pixel Format Image	16
6.2 The input data format.....	16
6.3 Signal Description	17
6.4 Timing Characteristics.....	19
6.5 Timing diagram	20
6.6 Power ON/OFF Sequence	21
7.0 Connector & Pin Assignment.....	22
7.1 TFT LCD Module.....	22
7.1.1 Pin Assignment.....	22
7.2 Connector on Backlight Unit.	23
7.2.1 Pin assignment	23
8.0 Reliability Test.....	24
9.0 Shipping Label	25
10.0 Mechanical Characteristics	26
11. Packing Specification	28

1.0 Handling Precautions

- 1) Since front polarizer is easily damaged, pay attention not to scratch it.
- 2) Be sure to turn off power supply when inserting or disconnecting from input connector.
- 3) Wipe off water drop immediately. Long contact with water may cause discoloration or spots.
- 4) When the panel surface is soiled, wipe it with absorbent cotton or other soft cloth.
- 5) Since the panel is made of glass, it may break or crack if dropped or bumped on hard surface.
- 6) Since CMOS LSI is used in this module, take care of static electricity and insure human earth when handling.
- 7) Do not open or modify the Module Assembly.
- 8) Do not press the reflector sheet at the back of the module to any directions.
- 9) In case if a Module has to be put back into the packing container slot after once it was taken out from the container, do not press the center of the LED lightbar edge. Instead, press at the far ends of the LED light bar edge softly. Otherwise the TFT Module may be damaged.
- 10) At the insertion or removal of the Signal Interface Connector, be sure not to rotate nor tilt the Interface Connector of the TFT Module.
- 11) After installation of the TFT Module into an enclosure, do not twist nor bend the TFT Module even momentary. At designing the enclosure, it should be taken into consideration that no bending/twisting forces are applied to the TFT Module from outside. Otherwise the TFT Module may be damaged.
- 12) Small amount of materials having no flammability grade is used in the LCD module. The LCD module should be supplied by power complied with requirements of Limited Power Source (IEC60950 or UL1950), or be applied exemption.
- 13) Pls avoid touching COF position while you are doing mechanical design
- 14) When storing modules as spares for a long time, the following precaution is necessary:
Store them in a dark place. Do not expose the module to sunlight or fluorescent light. Keep the temperature between 5°C and 35°C at normal humidity.

2.0 General Description

This specification applies to the 27 inch-FHD Color a-Si TFT-LCD Module M270HW01 V2. The display supports the FHD - 1920(H) x 1080(V) screen format and 16.7M colors (RGB 6-bits + Hi-FRC data). The light source of this TFT-LCD module is W-LED. All input signals are 2-channel LVDS interface and this module doesn't contain a driver for backlight.

2.1 Display Characteristics

The following items are characteristics summary on the table under 25°C condition:

ITEMS	Unit	SPECIFICATIONS
Screen Diagonal	[mm]	685.65(27")
Active Area	[mm]	597.6 (H) x 336.15 (V)
Pixels H x V		1920(x3) x 1080
Pixel Pitch	[um]	311.25 (per one triad) x311.25
Pixel Arrangement		R.G.B. Vertical Stripe
Display Mode		TN Mode, Normally White
White Luminance (Center)	[cd/m ²]	300 cd/m ² (Typ.)
Contrast Ratio		1000(Typ.)
Optical Response Time	[msec]	5ms (Typ., on/off)
Nominal Input Voltage VDD	[Volt]	+5.0 V (Typ)
Power Consumption (VDD line + LED line)	[Watt]	27.26 (Typ)
Weight	[Grams]	2860
Physical Size	[mm]	630(W) x 368.2(H) x 14.1(D) typ
Electrical Interface		Dual channel LVDS
Support Color		16.7M colors (RGB 6-bit + Hi-FRC)
Surface Treatment		Anti-Glare, 3H
Temperature Range		
Operating	[°C]	0 to +50
Storage (Shipping)	[°C]	-20 to +60
RoHS Compliance		RoHS Compliance
TCO Compliance		TCO 03 Compliance

2.2 Optical Characteristics

The optical characteristics are measured under stable conditions at 25°C :

Item	Unit	Conditions	Min.	Typ.	Max.	Note
Viewing Angle	[degree]	Horizontal (Right) CR = 10 (Left)	75 75	85 85	- -	2
		Vertical (Up) CR = 10 (Down)	70 70	80 80	- -	
Contrast ratio		Normal Direction	600	1000	-	3
Response Time	[msec]	Raising Time (T _{rR})	-	3.5	7.4	4
		Falling Time (T _{rF})	-	1.5	2.6	
		Raising + Falling	-	5	10	
		Gray to Gray(16x16 avg.)				
Color / Chromaticity Coordinates (CIE)		Red x	0.612	0.642	0.672	5
		Red y	0.315	0.345	0.375	
		Green x	0.292	0.322	0.352	
		Green y	0.601	0.631	0.651	
		Blue x	0.124	0.154	0.184	
		Blue y	0.022	0.052	0.082	
Color Coordinates (CIE) White		White x	0.283	0.313	0.343	
		White y	0.299	0.329	0.359	
Central Luminance	[cd/m ²]		240	300	-	6
Luminance Uniformity	[%]		75	80	-	7
Crosstalk (in 60Hz)	[%]				1.5	8
Flicker	dB				-20	9

Note 1: Measurement method

The LCD module should be stabilized at given temperature for 30 minutes to avoid abrupt temperature change during measuring (at surface 35°C). In order to stabilize the luminance, the measurement should be executed after lighting Backlight for 30 minutes in a stable, windless and dark room.

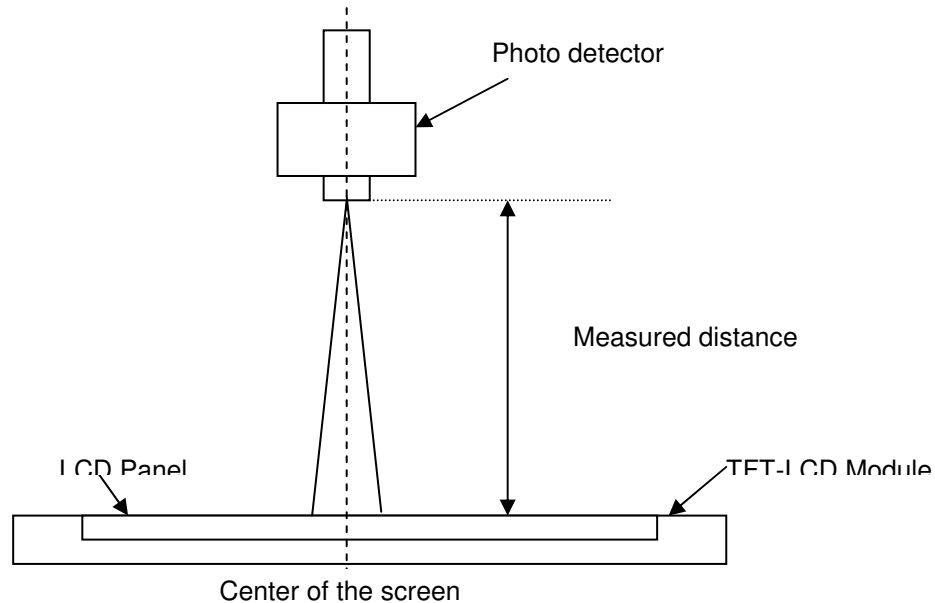

Note 2: Definition of viewing angle measured by ELDIM (EZContrast 88)

Viewing angle is the measurement of contrast ratio ≥ 10 , at the screen center, over a 180° horizontal and 180° vertical range (off-normal viewing angles). The 180° viewing angle range is broken down as follows; 90° (θ) horizontal left and right and 90° (ϕ) vertical, high (up) and low (down). The measurement direction is typically perpendicular to the display surface with the screen rotated about its center to develop the desired measurement viewing angle.

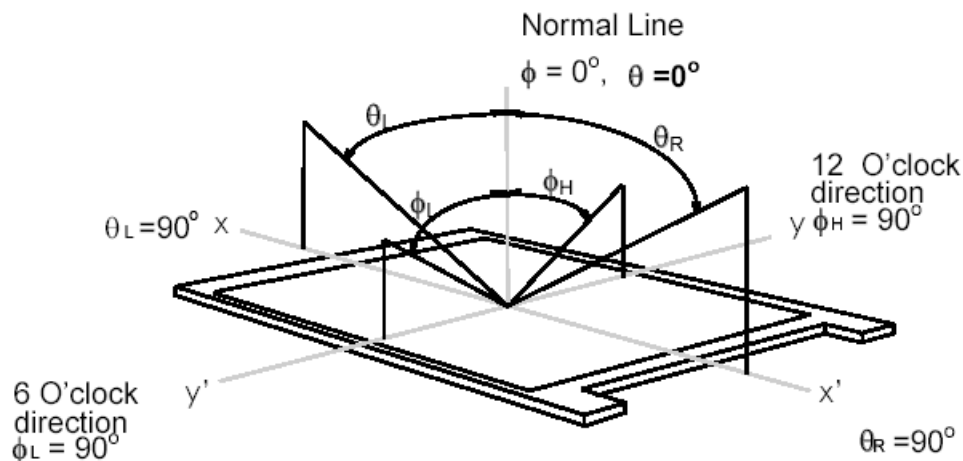

Note 3: Contrast ratio is measured by TOPCON SR-3

Note 4: Definition of Response time measured by Westar TRD-100A

The output signals of photo detector are measured when the input signals are changed from “Full Black” to “Full White” (rising time, T_{rR}), and from “Full White” to “Full Black” (falling time, T_{rF}), respectively. The response time is interval between the 10% and 90% (1 frame at 60 Hz) of amplitudes.

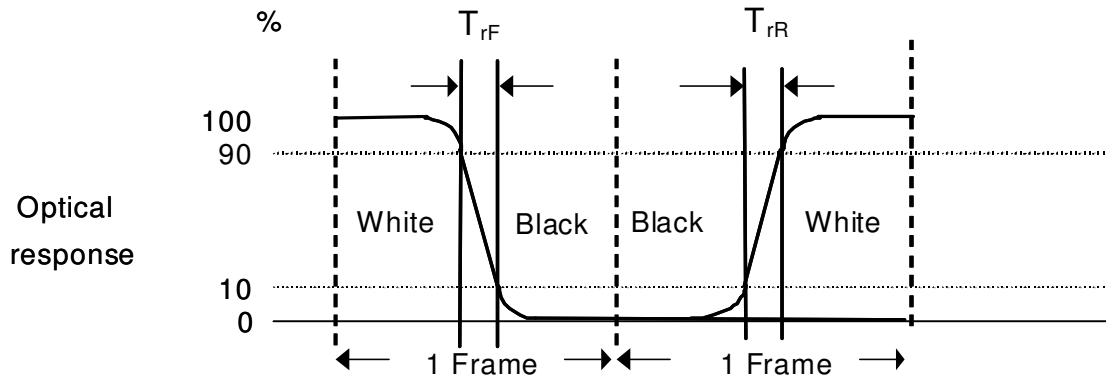

$T_{rR} + T_{rF} = 5$ msec (typ.).

Algorithm: \square Gray Level A – Gray Level B $\square \geq 16$, then the average gray to gray response time is 2 ms,

(F= 60 Hz).

Note 5: Color chromaticity and coordinates (CIE) is measured by TOPCON SR-3

Note 6: Central luminance is measured by TOPCON SR-3

Note 7: Luminance uniformity of these 9 points is defined as below and measured by TOPCON SR-3

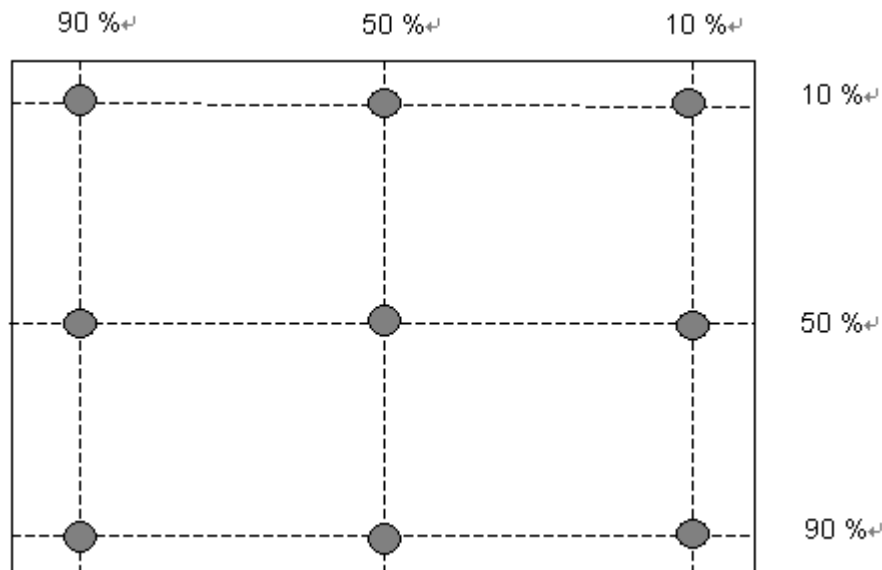

$$\text{Uniformity} = \frac{\text{Minimum Luminance in 9 points (1-9)}}{\text{Maximum Luminance in 9 Points (1-9)}}$$

Note 8: Crosstalk is defined as below and measured by TOPCON SR-3

$$CT = | YB - YA | / YA \times 100 (\%)$$

Where

YA = Luminance of measured location without gray level 0 pattern (cd/m²)

YB = Luminance of measured location with gray level 0 pattern (cd/m²)

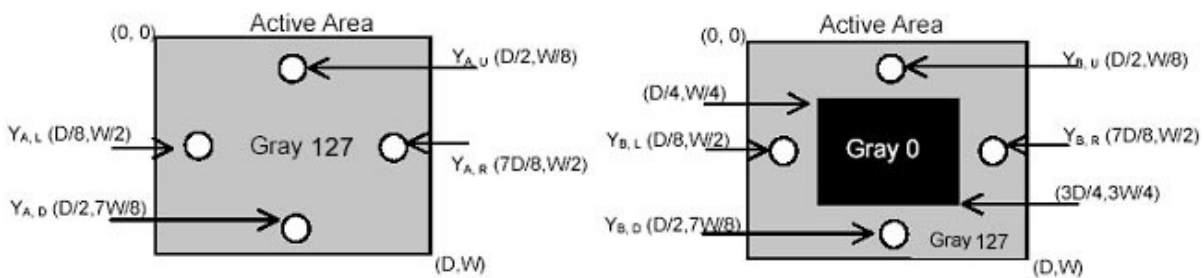

Note 9: Test Pattern: Subchecker Pattern measured by TOPCON SR-3

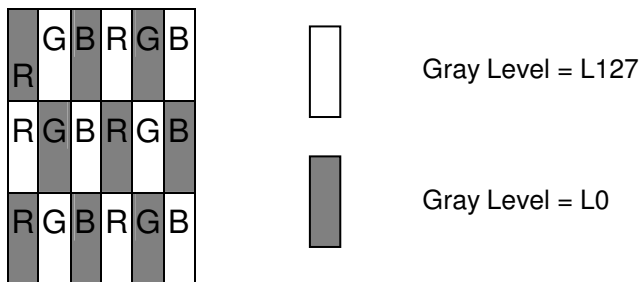

Method: Record dBV & DC value with TRD-100

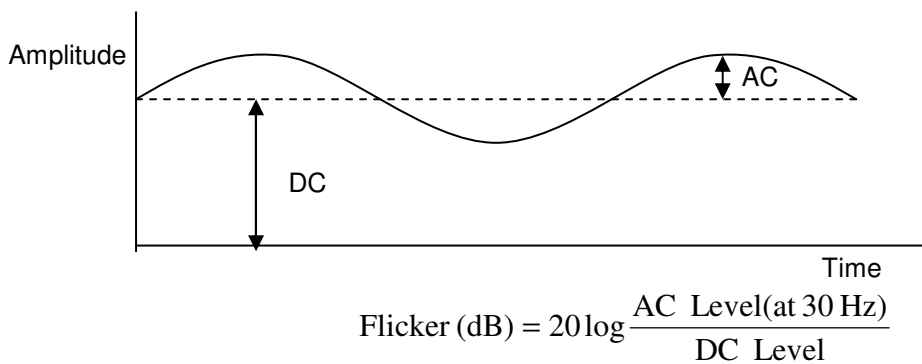

3.0 Functional Block Diagram

The following diagram shows the functional block of the 24.0 inch Color TFT-LCD Module:

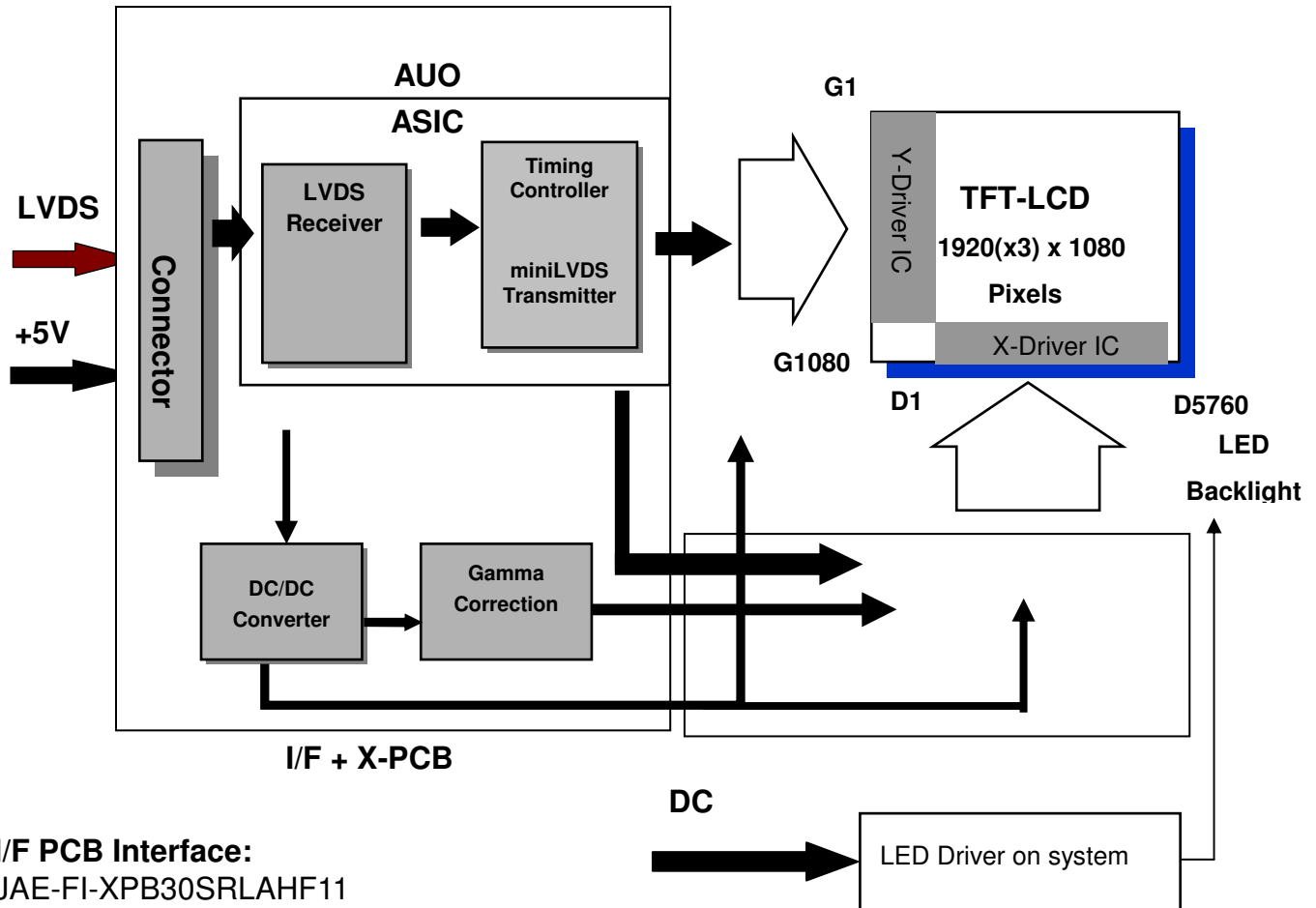

I/F PCB Interface:

JAE-FI-XPB30SRLAHF11

STM- MSCK2407P30

P-TWO- 01-187121-30091-3(A)

Mating Type:

FI-X30HL(Locked Type)

4.0 Absolute Maximum Ratings

Absolute maximum ratings of the module are as following:

4.1 TFT LCD Module

Item	Symbol	Min	Max	Unit	Conditions
Logic/LCD Drive Voltage	VDD	0	6.0	[Volt]	Note 1,2

4.2 Backlight Unit

Item	Symbol	Min	Max	Unit	Conditions
LED Current	ILED	120	126	[mA]	Note 1,2

4.3 Absolute Ratings of Environment

Item	Symbol	Min.	Max.	Unit	Conditions
Operating Temperature	TOP	0	+50	[°C]	Note 3
Glass surface temperature (operation)	TGS	0	+65	[°C]	Note 3, Note 4
Operation Humidity	HOP	5	90	[%RH]	Note 3
Storage Temperature	TST	-20	+60	[°C]	
Storage Humidity	HST	5	90	[%RH]	

Note 1: With in Ta (25°C)

Note 2: Permanent damage to the device may occur if exceeding maximum values

Note 3: Temperature and relative humidity range are shown as the below figure.

1. 90% RH Max (Ta ≤ 39°C)
2. Max wet-bulb temperature at 39°C or less. (Ta ≤ 39°C)
3. No condensation

Note 4: Function Judged only

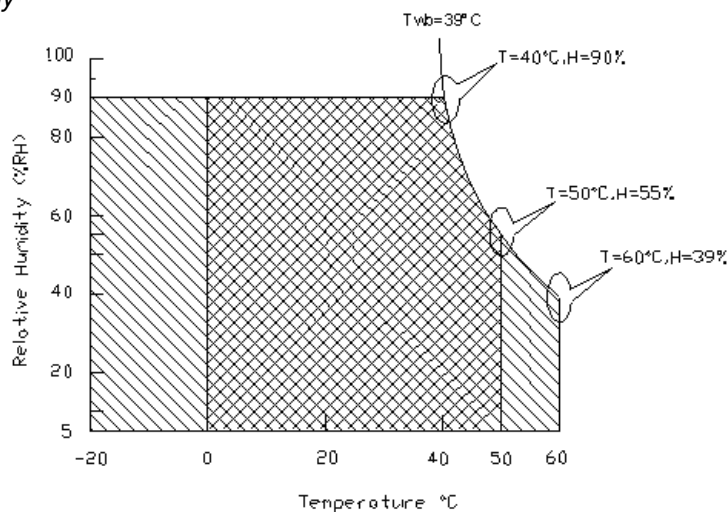

Operating Range



Storage Range

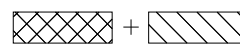

5.0 Electrical characteristics

5.1 TFT LCD Module

5.1.1 Power Specification

Input power specifications are as following:

Symbol	Parameter	Min	Typ	Max	Unit	Conditions
VDD	Logic/LCD Drive Voltage	4.5	5.0	5.5	[Volt]	+/-10%
IDD	Input Current	-	0.7	1	[A]	VDD= 5.0V, All Black Pattern At 60Hz,
		-	-	-	-	-
PDD	VDD Power	-	3.5	5.5	[Watt]	VDD= 5.0V, All Black Pattern At 60Hz
		-	-	-	-	-
IRush	Inrush Current	-	-	2	[A]	Note 1
VDDrp	Allowable Logic/LCD Drive Ripple Voltage	-	-	500	[mV] p-p	VDD= 5.0V, All Black Pattern At 75Hz

Note 1: Measurement conditions:

The duration of rising time of power input is 470us.

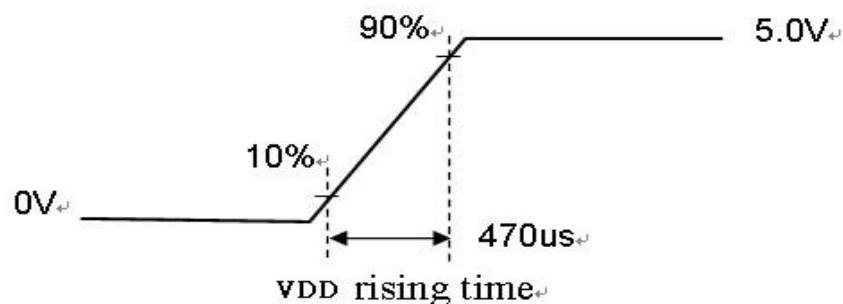
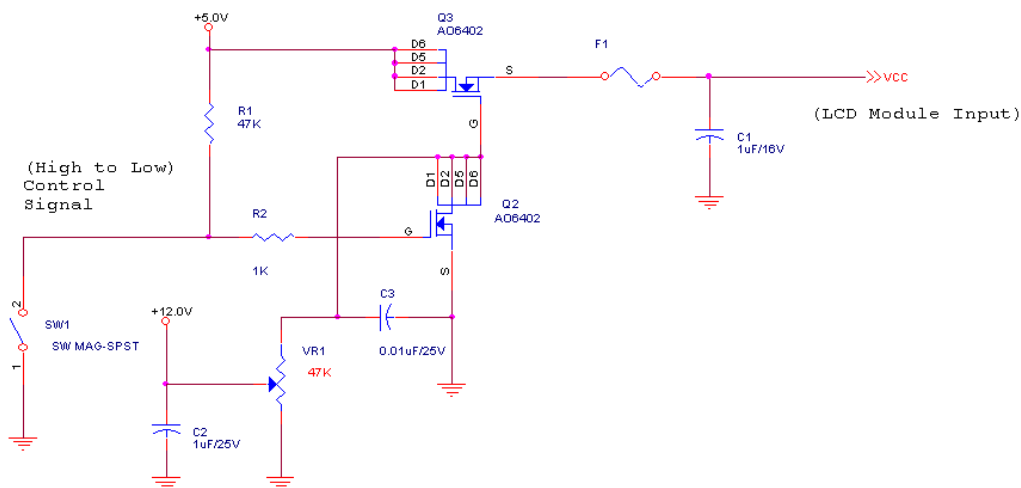

5.1.2 Signal Electrical Characteristics

Input signals shall be low or Hi-Z state when VDD is off. Please refer to specifications of SN75LVDS82DGG (Texas Instruments) in detail.

1. DC Characteristics of each signal are as following:

Symbol	Parameter	Min	Typ	Max	Units	Condition
V_{TH}	Differential Input High Threshold	-	-	+100	[mV]	$V_{CM} = 1.2V$ Note 1
V_{TL}	Differential Input Low Threshold	-100	-	-	[mV]	$V_{CM} = 1.2V$ Note 1
$ V_{ID} $	Input Differential Voltage	100	-	600	[mV]	Note 1
V_{CM}	Differential Input Common Mode Voltage	+1.0	+1.2	+1.5	[V]	$V_{TH} - V_{TL} = 200MV$ (max) Note 1

Note 1: LVDS Signal Waveform

Single-End

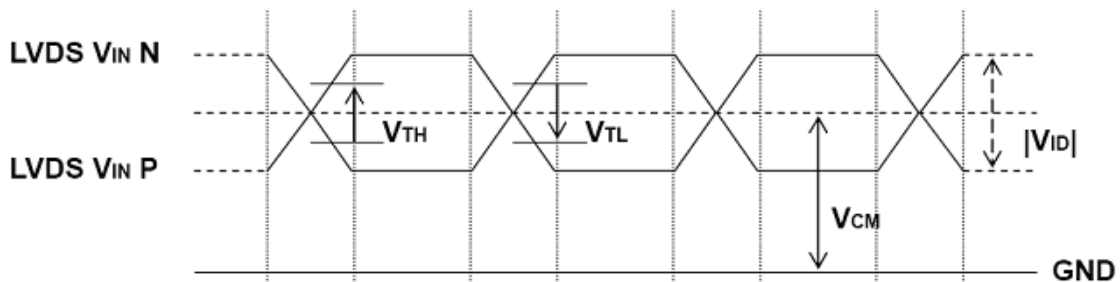

Differential Signal

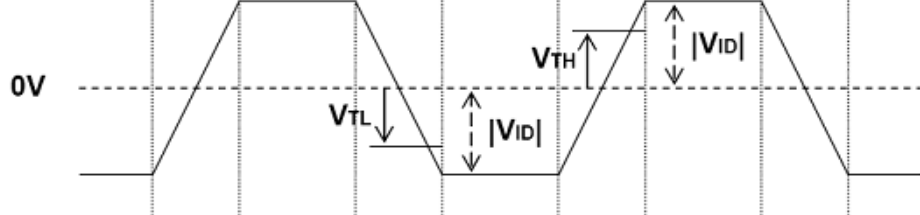

2. AC Characteristics

Description	Symbol	Min	Max	Unit	Note
Maximum deviation of input clock frequency during SSC	F_{DEV}	-	± 3	%	
Maximum modulation frequency of input clock during SSC	F_{MOD}	-	300	KHz	

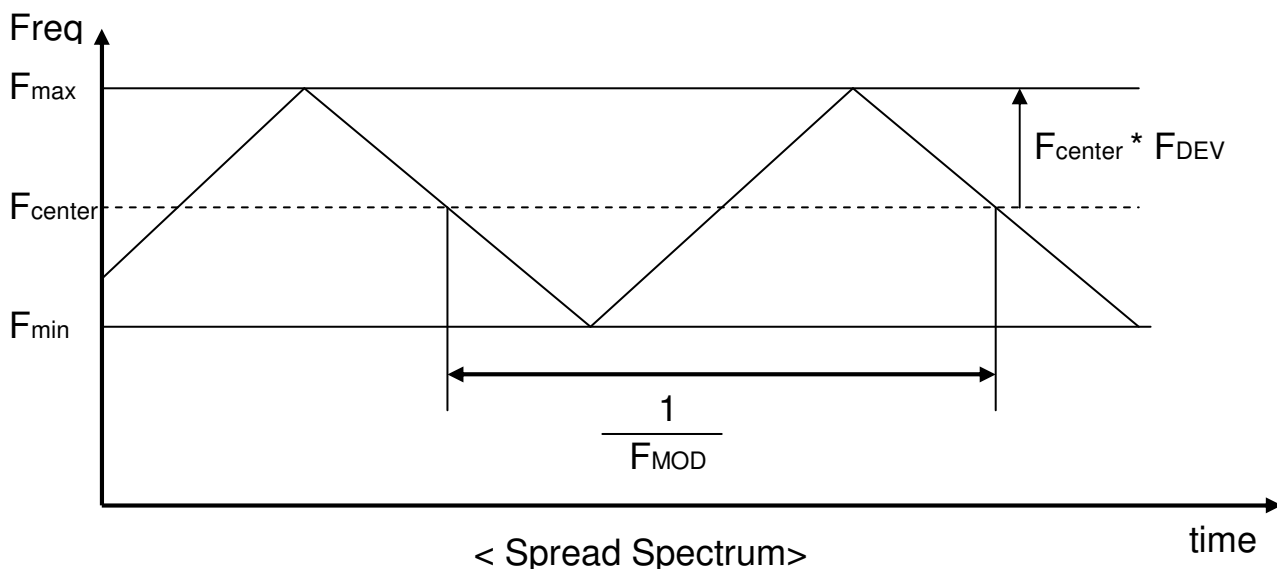

5.2 Backlight Unit

Parameter guideline for LED driving is under stable conditions at 25°C (Room Temperature):

Symbol	Parameter	Min.	Typ.	Max.	Unit	Note
$I_{R_{LED}}$	LED Operation Current	-	120	126	[mA] Note 1	Operating with fixed driving current
V_{LB}	Light Bar Operation Voltage (for reference)	-	49.5	54	[Volt] Note 2	
P_{BLU}	BLU Power consumption (for reference)	-	23.76	27.22	[Watt]	
LT_{LED}	LED life Time (Typical)	30,000	-	-	[Hour] Note 3	

Note 1 :The specified current is input LED chip 100% duty current.

Note 2 : The value showed in the table is one light bar's operation voltage.

Note 3 : Definition of life time : brightness becomes 50% of its original value. The minimum life time of LED unit is on the condition of $I_{R_{LED}} = 120mA$ and $25\pm 2^{\circ}C$ (Room temperature).

Note 4: Each LED light bar consists of 60 pcs LED package (4 strings x 15 pcs / string).

6.0 Signal Characteristic

6.1 Pixel Format Image

Following figure shows the relationship of the input signals and LCD pixel format.

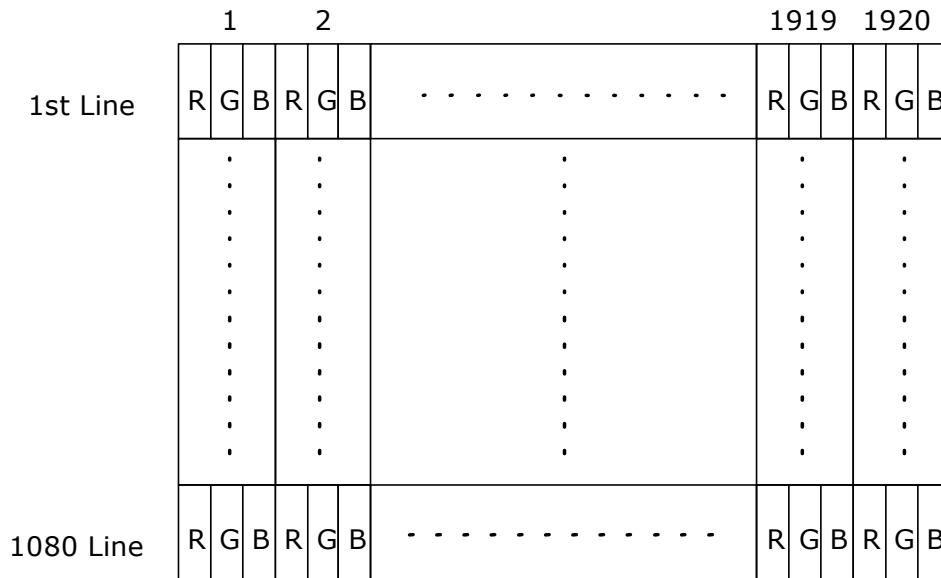

6.2 The input data format

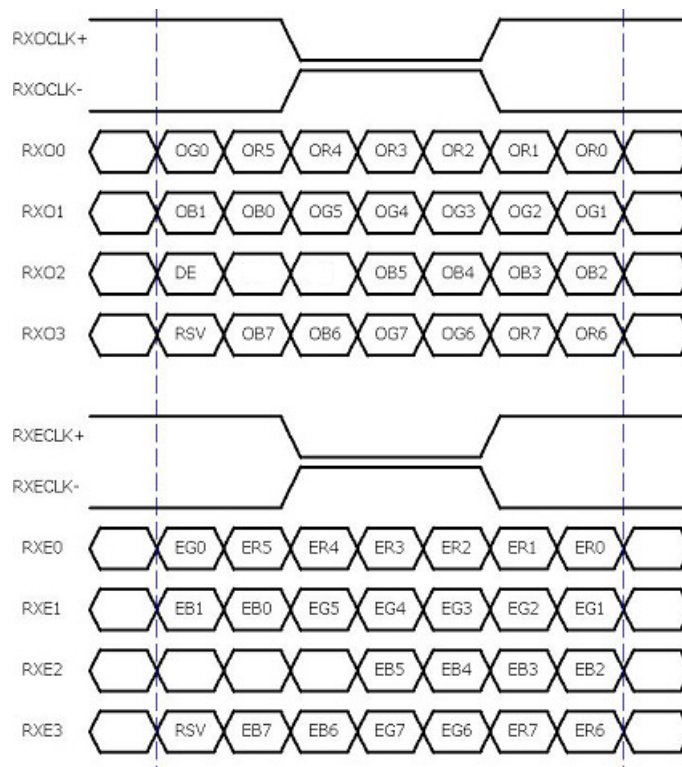

Note 1: R/G/B data 7:MSB, R/G/B data 0:LSB O = "Odd Pixel Data" E = "Even Pixel Data"

6.3 Signal Description

The module using one LVDS receiver SN75LVDS82(Texas Instruments). LVDS is a differential signal technology for LCD interface and high speed data transfer device. LVDS transmitters shall be SN75LVDS83(negative edge sampling). The first LVDS port(RxOxxx) transmits odd pixels while the second LVDS port(RxExxx) transmits even pixels.

PIN #	SIGNAL NAME	DESCRIPTION
1	RxOIN0-	Negative LVDS differential data input (Odd data)
2	RxOIN0+	Positive LVDS differential data input (Odd data)
3	RxOIN1-	Negative LVDS differential data input (Odd data)
4	RxOIN1+	Positive LVDS differential data input (Odd data)
5	RxOIN2-	Negative LVDS differential data input (Odd data, DSPTMG)
6	RxOIN2+	Positive LVDS differential data input (Odd data, DSPTMG)
7	GND	Power Ground
8	RxOCLK-	Negative LVDS differential clock input (Odd clock)
9	RxOCLK+	Positive LVDS differential clock input (Odd clock)
10	RxOIN3-	Negative LVDS differential data input (Odd data)
11	RxOIN3+	Positive LVDS differential data input (Odd data)
12	RxEIN0-	Negative LVDS differential data input (Even data)
13	RxEIN0+	Positive LVDS differential data input (Even data)
14	GND	Power Ground
15	RxEIN1-	Positive LVDS differential data input (Even data)
16	RxEIN1+	Negative LVDS differential data input (Even data)
17	GND	Power Ground
18	RxEIN2-	Negative LVDS differential data input (Even data)
19	RxEIN2+	Positive LVDS differential data input (Even data)
20	RxECLK-	Negative LVDS differential clock input (Even clock)
21	RxECLK+	Positive LVDS differential clock input (Even clock)
22	RxEIN3-	Negative LVDS differential data input (Even data)
23	RxEIN3+	Positive LVDS differential data input (Even data)
24	GND	Power Ground
25	NC	No connection (for AUO test only. Do not connect)
26	NC	No connection (for AUO test only. Do not connect)
27	NC	No connection (for AUO test only. Do not connect)
28	VDD	Power +5V
29	VDD	Power +5V
30	VDD	Power +5V

Note1: Start from left side

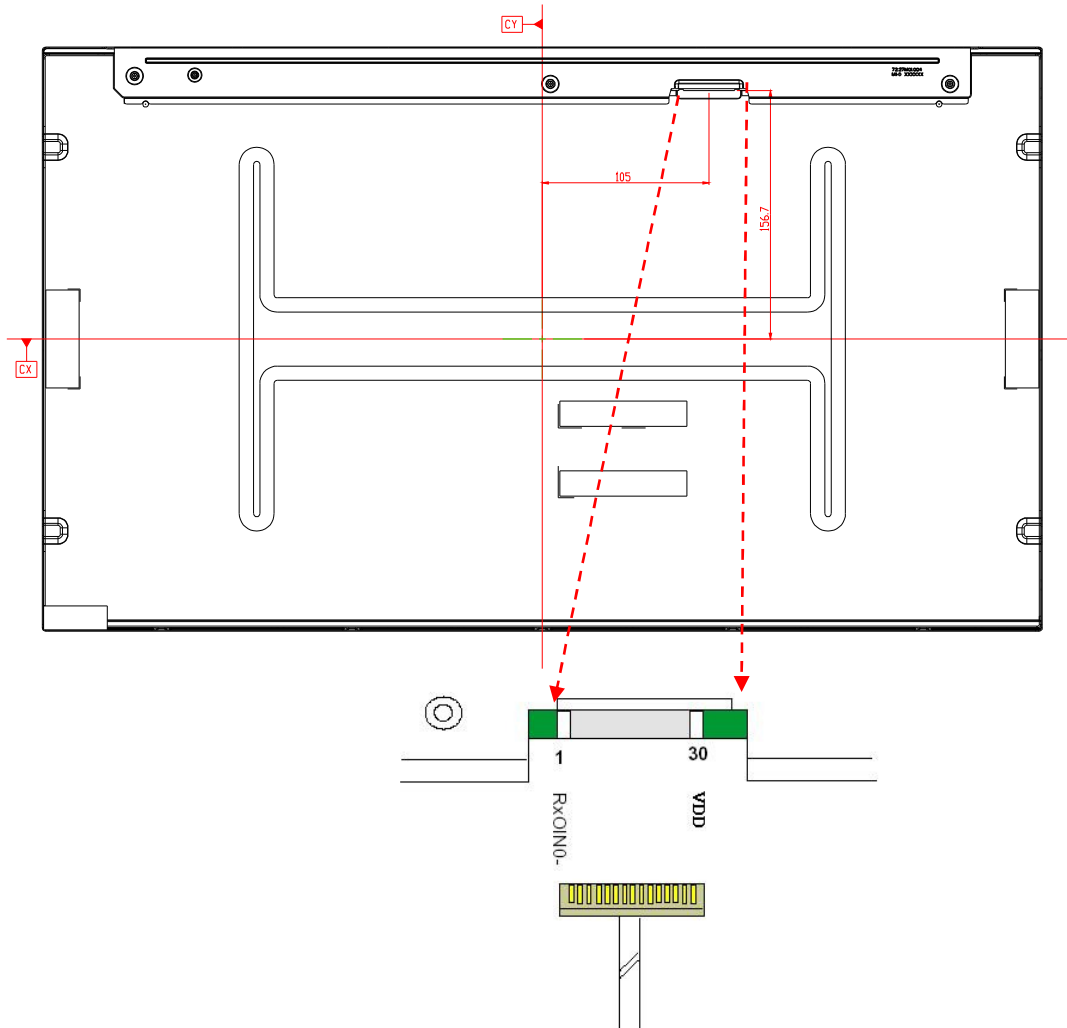

Note2: Input signals of odd and even clock shall be the same timing.

6.4 Timing Characteristics

Basically, interface timing described here is not actual input timing of LCD module but close to output timing of SN75LVDS82DGG (Texas Instruments) or equivalent.

Signal	Item	Symbol	Min	Typ	Max	Unit
Vertical Section	Period	T_v	1088	1130	2047	Th
	Active	$T_{disp(v)}$	1080	1080	1080	Th
	Blanking	$T_{bp(v)}+T_{fp(v)}+PW_{vs}$	8	50	967	Th
Horizontal Section	Period	T_h	1000	1050	2047	Tclk
	Active	$T_{disp(h)}$	960	960	960	Tclk
	Blanking	$T_{bp(h)}+T_{fp(h)}+PW_{hs}$	40	90	1087	Tclk
Clock	Period	Tclk	25	13.3	11.1	ns
	Frequency	Freq	40	75	90	MHz
Frame rate	Frame rate	F	50	60	75	Hz

Note : DE mode only

6.5 Timing diagram

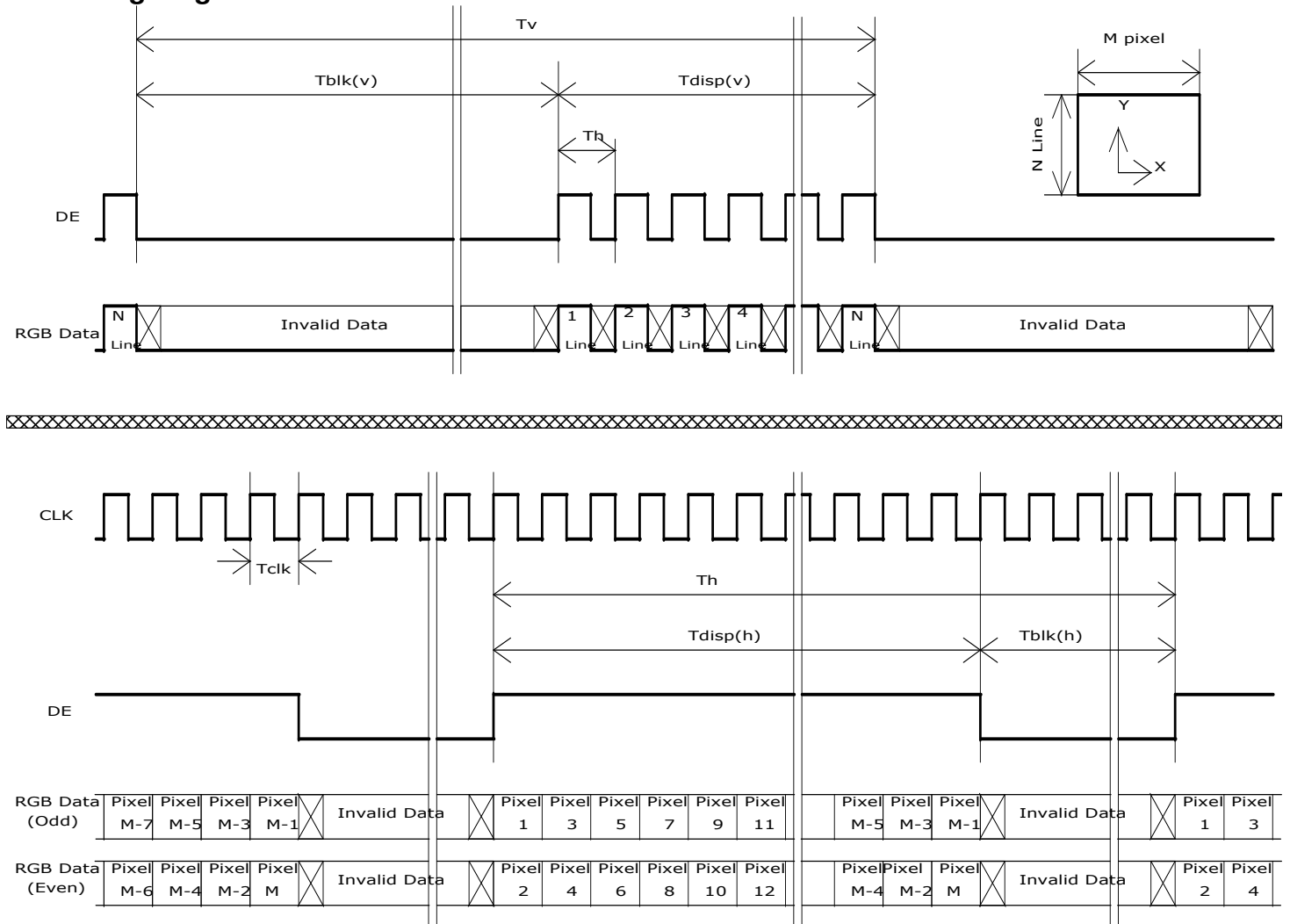

6.6 Power ON/OFF Sequence

VDD power and lamp on/off sequence are as follows. Interface signals are also shown in the chart. Signals from any system shall be Hi-Z state or low level when VDD is off.

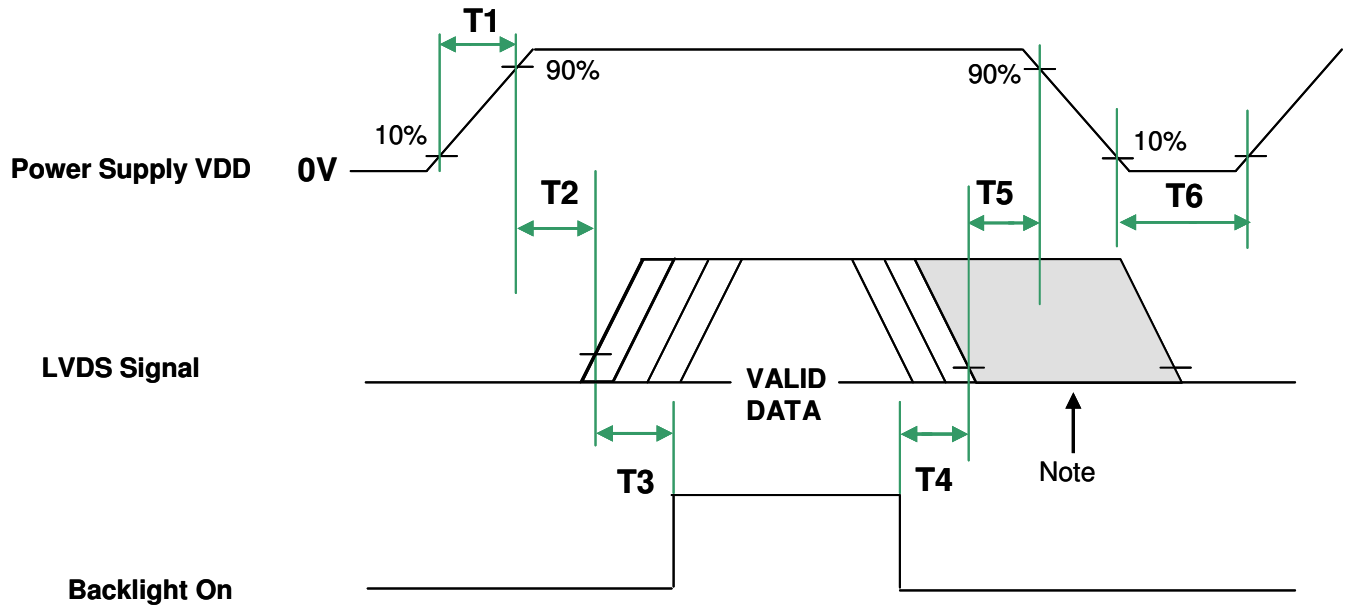

Note : Insert a white pattern after valid data and last until VDD falls to 10%

Parameter	Value		Unit
	Min.	Max.	
T1	0.5	10	[msec]
T2	0	50	[msec]
T3	500	-	[msec]
T4	200	-	[msec]
T5	40	-	[msec]
T6	1000	-	[msec]

7.0 Connector & Pin Assignment

Physical interface is described as for the connector on module. These connectors are capable of accommodating the following signals and will be following components.

7.1 TFT LCD Module

Connector Name / Designation	Interface Connector / Interface card
Manufacturer	JAE STM P-TWO
Type Part Number	FI-XPB30SRLAHF11 MSCK2407P30 01-187121-30091-3(A)
Mating Housing Part Number	FI-X30HL (Locked Type)

7.1.1 Pin Assignment

Pin#	Signal Name	Pin#	Signal Name
1	RxOIN0-	2	RxOIN0+
3	RxOIN1-	4	RxOIN1+
5	RxOIN2-	6	RxOIN2+
7	GND	8	RxOCLKIN-
9	RxOCLKIN+	10	RxOIN3-
11	RxOIN3+	12	RxEIN0-
13	RxEIN0+	14	GND
15	RxEIN1-	16	RxEIN1+
17	GND	18	RxEIN2-
19	RxEIN2+	20	RxECLKIN-
21	RxECLKIN+	22	RxEIN3-
23	RxEIN3+	24	GND
25	NC (for AUO test only. Do not connect)	26	NC (for AUO test only. Do not connect)
27	NC (for AUO test only. Do not connect)	28	VDD
29	VDD	30	VDD

7.2 Connector on Backlight Unit.

This connector is mounted on LED light-bar.

Connector Name / Designation	Light Bar Connector
Manufacturer	ENTERY INDUSTRIAL CO., LTD
Type Part Number	3707K-Q06N-01R (Locking Type)

7.2.1 Pin assignment

Pin no.	Signal name
1	IRLED (current out)
2	IRLED (current out)
3	VLED (voltage in)
4	VLED (voltage in)
5	IRLED (current out)
6	IRLED (current out)

8.0 Reliability Test

Environment test conditions are listed as following table.

Items	Required Condition	Note
Temperature Humidity Bias (THB)	Ta= 50°C , 80%RH, 300hours	
High Temperature Operation (HTO)	Ta= 50°C , 50%RH, 300hours	
Low Temperature Operation (LTO)	Ta= 0°C , 300hours	
High Temperature Storage (HTS)	Ta= 60°C , 300hours	
Low Temperature Storage (LTS)	Ta= -20°C , 300hours	
Vibration Test (Non-operation)	Acceleration: 1.5 Grms Wave: Random Frequency: 10 - 200 Hz Duration: 30 Minutes each Axis (X, Y, Z)	
Shock Test (Non-operation)	Acceleration: 50 G Wave: Half-sine Active Time: 20 ms Direction: ±X, ±Y, ±Z (one time for each Axis)	
Drop Test	Height: 46 cm, package test	
Thermal Shock Test (TST)	-20°C/30min, 60°C/30min, 100 cycles	1
On/Off Test	On/10sec, Off/10sec, 30,000 cycles	
ESD (Electro Static Discharge)	Contact Discharge: ± 8KV, 150pF(330Ω) 1sec, 15 points, 25 times/ point.	2
	Air Discharge: ± 15KV, 150pF(330Ω) 1sec 15 points, 25 times/ point.	
Altitude Test	Operation:10,000 ft Non-Operation:30,000 ft	

Note 1: The TFT-LCD module will not sustain damage after being subjected to 100 cycles of rapid temperature change. A cycle of rapid temperature change consists of varying the temperature from -20°C to 60°C, and back again. Power is not applied during the test. After temperature cycling, the unit is placed in normal room ambient for at least 4 hours before power on.

Note 2: EN61000-4-2, ESD class B: Certain performance degradation allowed
 No data lost
 Self-recoverable
 No hardware failures.

9.0 Shipping Label

The label is on the panel as shown below:

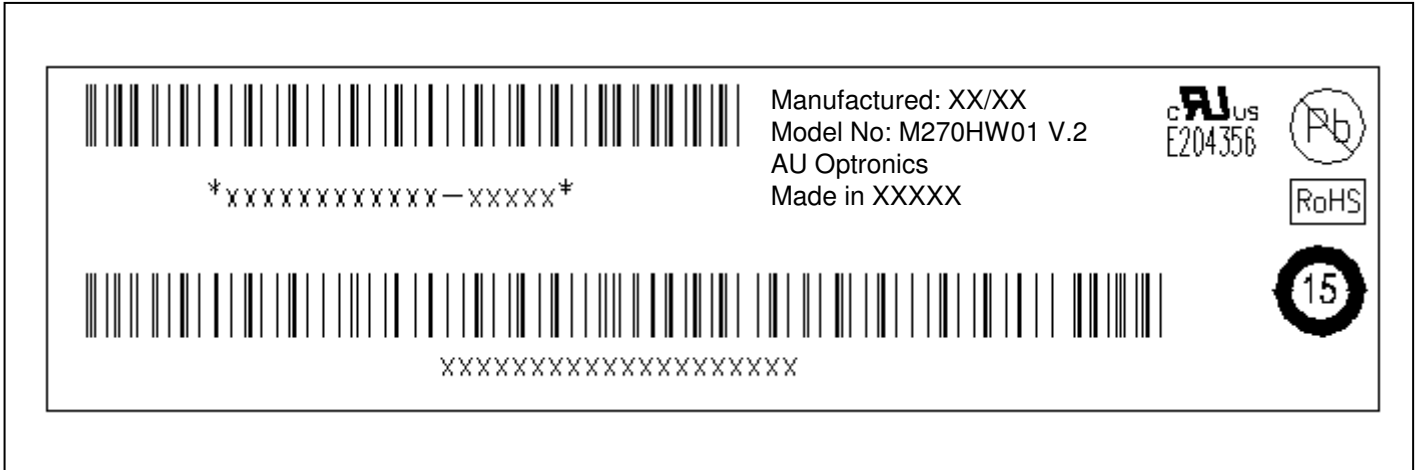

Note 1: For Pb Free products, AUO will add  for identification.

Note 2: For RoHS compatible products, AUO will add  for identification.

Note 3: For China RoHS compatible products, AUO will add  for identification.

Note 4: The Green Mark will be presented only when the green documents have been ready by AUO Internal Green Team.

10.0 Mechanical Characteristics

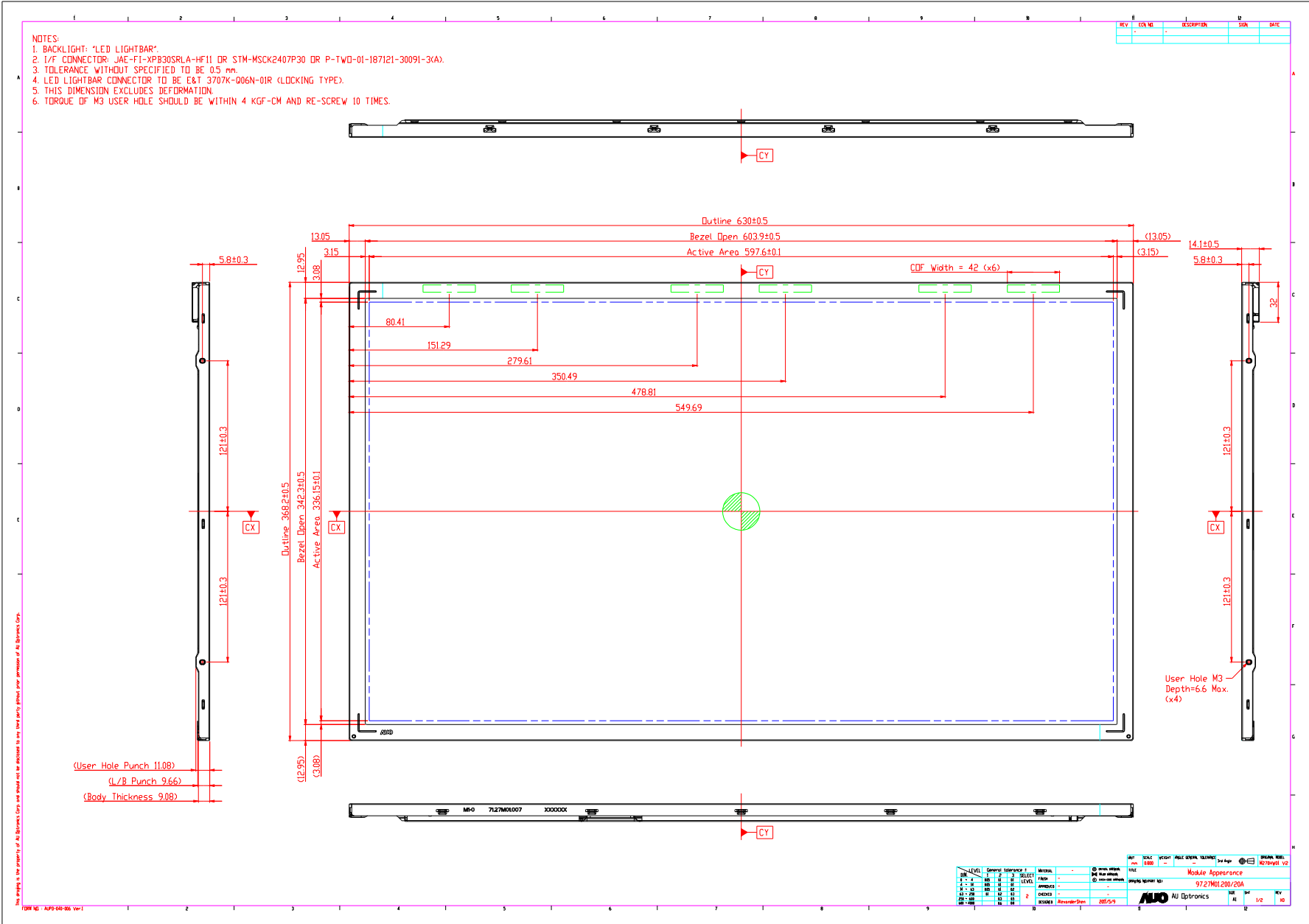

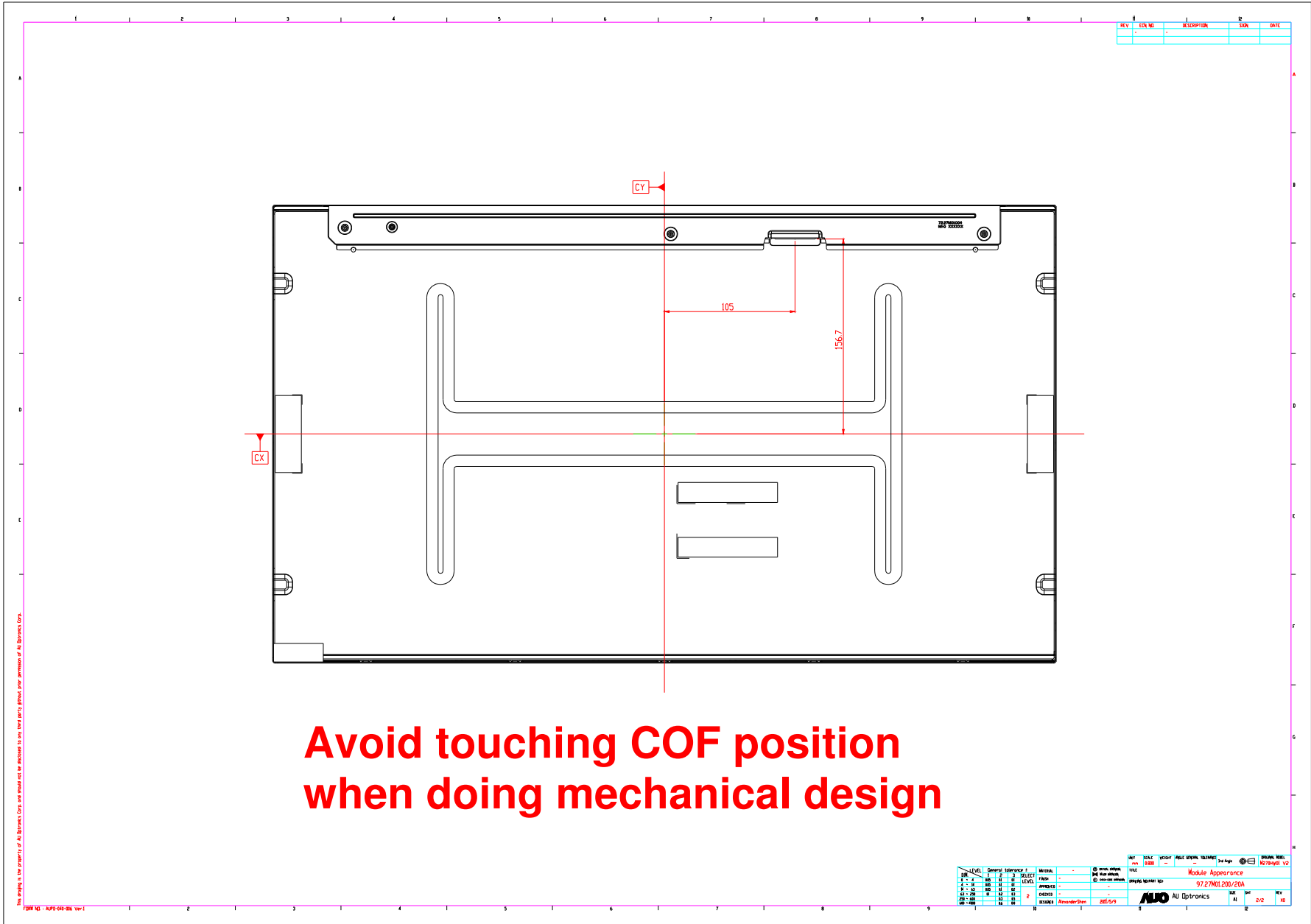

REV	COL NO	DESCRIPTION	DATE

**Avoid touching COF position
when doing mechanical design**

This sample is the property of AU Optronics Corp. and should not be released to any third party without prior permission of AU Optronics Corp.

LEVEL	GENERAL	REFERENCE	SYMBOL	VALUE	UNIT	SCALE	HEIGHT	ANGLE	TOLERANCE	SHOW	HIDE
1	DRILL		DRILL			1:1	1.5	0	±0.02		
2	PLATE		PLATE			1:1	0.5	0	±0.02		
3	APPROX		APPROX			1:1	0.5	0	±0.02		
4	DRILL		DRILL			1:1	1.5	0	±0.02		
5	DRILL		DRILL			1:1	1.5	0	±0.02		
6	DRILL		DRILL			1:1	1.5	0	±0.02		
7	DRILL		DRILL			1:1	1.5	0	±0.02		
8	DRILL		DRILL			1:1	1.5	0	±0.02		
9	DRILL		DRILL			1:1	1.5	0	±0.02		
10	DRILL		DRILL			1:1	1.5	0	±0.02		
11	DRILL		DRILL			1:1	1.5	0	±0.02		
12	DRILL		DRILL			1:1	1.5	0	±0.02		
13	DRILL		DRILL			1:1	1.5	0	±0.02		
14	DRILL		DRILL			1:1	1.5	0	±0.02		
15	DRILL		DRILL			1:1	1.5	0	±0.02		
16	DRILL		DRILL			1:1	1.5	0	±0.02		
17	DRILL		DRILL			1:1	1.5	0	±0.02		
18	DRILL		DRILL			1:1	1.5	0	±0.02		
19	DRILL		DRILL			1:1	1.5	0	±0.02		
20	DRILL		DRILL			1:1	1.5	0	±0.02		
21	DRILL		DRILL			1:1	1.5	0	±0.02		
22	DRILL		DRILL			1:1	1.5	0	±0.02		
23	DRILL		DRILL			1:1	1.5	0	±0.02		
24	DRILL		DRILL			1:1	1.5	0	±0.02		
25	DRILL		DRILL			1:1	1.5	0	±0.02		
26	DRILL		DRILL			1:1	1.5	0	±0.02		
27	DRILL		DRILL			1:1	1.5	0	±0.02		
28	DRILL		DRILL			1:1	1.5	0	±0.02		
29	DRILL		DRILL			1:1	1.5	0	±0.02		
30	DRILL		DRILL			1:1	1.5	0	±0.02		
31	DRILL		DRILL			1:1	1.5	0	±0.02		
32	DRILL		DRILL			1:1	1.5	0	±0.02		
33	DRILL		DRILL			1:1	1.5	0	±0.02		
34	DRILL		DRILL			1:1	1.5	0	±0.02		
35	DRILL		DRILL			1:1	1.5	0	±0.02		
36	DRILL		DRILL			1:1	1.5	0	±0.02		
37	DRILL		DRILL			1:1	1.5	0	±0.02		
38	DRILL		DRILL			1:1	1.5	0	±0.02		
39	DRILL		DRILL			1:1	1.5	0	±0.02		
40	DRILL		DRILL			1:1	1.5	0	±0.02		
41	DRILL		DRILL			1:1	1.5	0	±0.02		
42	DRILL		DRILL			1:1	1.5	0	±0.02		
43	DRILL		DRILL			1:1	1.5	0	±0.02		
44	DRILL		DRILL			1:1	1.5	0	±0.02		
45	DRILL		DRILL			1:1	1.5	0	±0.02		
46	DRILL		DRILL			1:1	1.5	0	±0.02		
47	DRILL		DRILL			1:1	1.5	0	±0.02		
48	DRILL		DRILL			1:1	1.5	0	±0.02		
49	DRILL		DRILL			1:1	1.5	0	±0.02		
50	DRILL		DRILL			1:1	1.5	0	±0.02		
51	DRILL		DRILL			1:1	1.5	0	±0.02		
52	DRILL		DRILL			1:1	1.5	0	±0.02		
53	DRILL		DRILL			1:1	1.5	0	±0.02		
54	DRILL		DRILL			1:1	1.5	0	±0.02		
55	DRILL		DRILL			1:1	1.5	0	±0.02		
56	DRILL		DRILL			1:1	1.5	0	±0.02		
57	DRILL		DRILL			1:1	1.5	0	±0.02		
58	DRILL		DRILL			1:1	1.5	0	±0.02		
59	DRILL		DRILL			1:1	1.5	0	±0.02		
60	DRILL		DRILL			1:1	1.5	0	±0.02		
61	DRILL		DRILL			1:1	1.5	0	±0.02		
62	DRILL		DRILL			1:1	1.5	0	±0.02		
63	DRILL		DRILL			1:1	1.5	0	±0.02		
64	DRILL		DRILL			1:1	1.5	0	±0.02		
65	DRILL		DRILL			1:1	1.5	0	±0.02		
66	DRILL		DRILL			1:1	1.5	0	±0.02		
67	DRILL		DRILL			1:1	1.5	0	±0.02		
68	DRILL		DRILL			1:1	1.5	0	±0.02		
69	DRILL		DRILL			1:1	1.5	0	±0.02		
70	DRILL		DRILL			1:1	1.5	0	±0.02		
71	DRILL		DRILL			1:1	1.5	0	±0.02		
72	DRILL		DRILL			1:1	1.5	0	±0.02		
73	DRILL		DRILL			1:1	1.5	0	±0.02		
74	DRILL		DRILL			1:1	1.5	0	±0.02		
75	DRILL		DRILL			1:1	1.5	0	±0.02		
76	DRILL		DRILL			1:1	1.5	0	±0.02		
77	DRILL		DRILL			1:1	1.5	0	±0.02		
78	DRILL		DRILL			1:1	1.5	0	±0.02		
79	DRILL		DRILL			1:1	1.5	0	±0.02		
80	DRILL		DRILL			1:1	1.5	0	±0.02		
81	DRILL		DRILL			1:1	1.5	0	±0.02		
82	DRILL		DRILL			1:1	1.5	0	±0.02		
83	DRILL		DRILL			1:1	1.5	0	±0.02		
84	DRILL		DRILL			1:1	1.5	0	±0.02		
85	DRILL		DRILL			1:1	1.5	0	±0.02		
86	DRILL		DRILL			1:1	1.5	0	±0.02		
87	DRILL		DRILL			1:1	1.5	0	±0.02		
88	DRILL		DRILL			1:1	1.5	0	±0.02		
89	DRILL		DRILL			1:1	1.5	0	±0.02		
90	DRILL		DRILL			1:1	1.5	0	±0.02		
91	DRILL		DRILL			1:1	1.5	0	±0.02		
92	DRILL		DRILL			1:1	1.5	0	±0.02		
93	DRILL		DRILL			1:1	1.5	0	±0.02		
94	DRILL		DRILL			1:1	1.5	0	±0.02		
95	DRILL		DRILL			1:1	1.5	0	±0.02		
96	DRILL		DRILL			1:1	1.5	0	±0.02		
97	DRILL		DRILL			1:1	1.5	0	±0.02		
98	DRILL		DRILL			1:1	1.5	0	±0.02		
99	DRILL		DRILL			1:1	1.5	0	±0.02		
100	DRILL		DRILL			1:1	1.5	0	±0.02		

